



## PRODUCT DATA SHEET BLACK PAW MODEL PTB5T HIGH CAPACITY PALLET TRUCK 3.5 TON, 7,000 LBS

The Black Paw 3.5-Ton Pallet Jack, the robust and dependable solution designed to revolutionize the way you handle heavy loads. Whether you're a seasoned warehouse professional or just starting to streamline your material handling processes, this pallet jack is your go-to tool for unparalleled efficiency and reliability.



- 3.5 ton (7,000 LBS) capacity
- Heavy Duty Construction
- Ergonomic controls
- Easy maintenance
- High traction
- Lowered for height
- Raised fork height
- Dimensions

**Heavy-Duty Performance:** With a hefty 3.5-ton weight capacity, the Black Paw Pallet Jack is more than capable of moving even your bulkiest loads with ease. Say goodbye to struggling with oversized or exceptionally heavy pallets.



**Precision Control:** The Black Paw Pallet Jack offers exceptional control and maneuverability, ensuring smooth, precise movement in tight spaces. Whether you're navigating crowded warehouses or loading trucks, this jack will quickly become your trusted companion.



**Durable Construction:** Crafted from high-quality materials, this pallet jack is built to withstand the rigors of daily use. Its rugged construction ensures a long lifespan, reducing the need for frequent replacements and saving you money in the long run.



**Comfortable Ergonomics:** The operator's comfort is a priority, with an ergonomic handle that reduces strain during extended use. Whether you're lifting, lowering, or steering, you'll appreciate the thoughtful design that keeps you comfortable and productive.

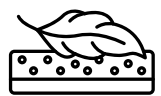

**Versatile Design:** The Black Paw 3.5-Ton Pallet Jack is adaptable to a wide range of applications. From manufacturing facilities to retail distribution centers and beyond, it's an indispensable tool for any business that relies on efficient material handling.



**Safety First:** Safety is paramount in any warehouse environment, and the Black Paw Pallet Jack comes equipped with safety features to protect both users and your valuable inventory. The non-slip, high-traction wheels ensure stable handling at all times.



**Easy Maintenance:** Simplify upkeep with this pallet jack's user-friendly design. Routine maintenance is a breeze, and the well-engineered components are readily accessible for any necessary repairs.





# PRODUCT DATA SHEET BLACK PAW MODEL PTBF3.5T HIGH CAPACITY PALLET TRUCK 3.5 TON, 7,000 LBS

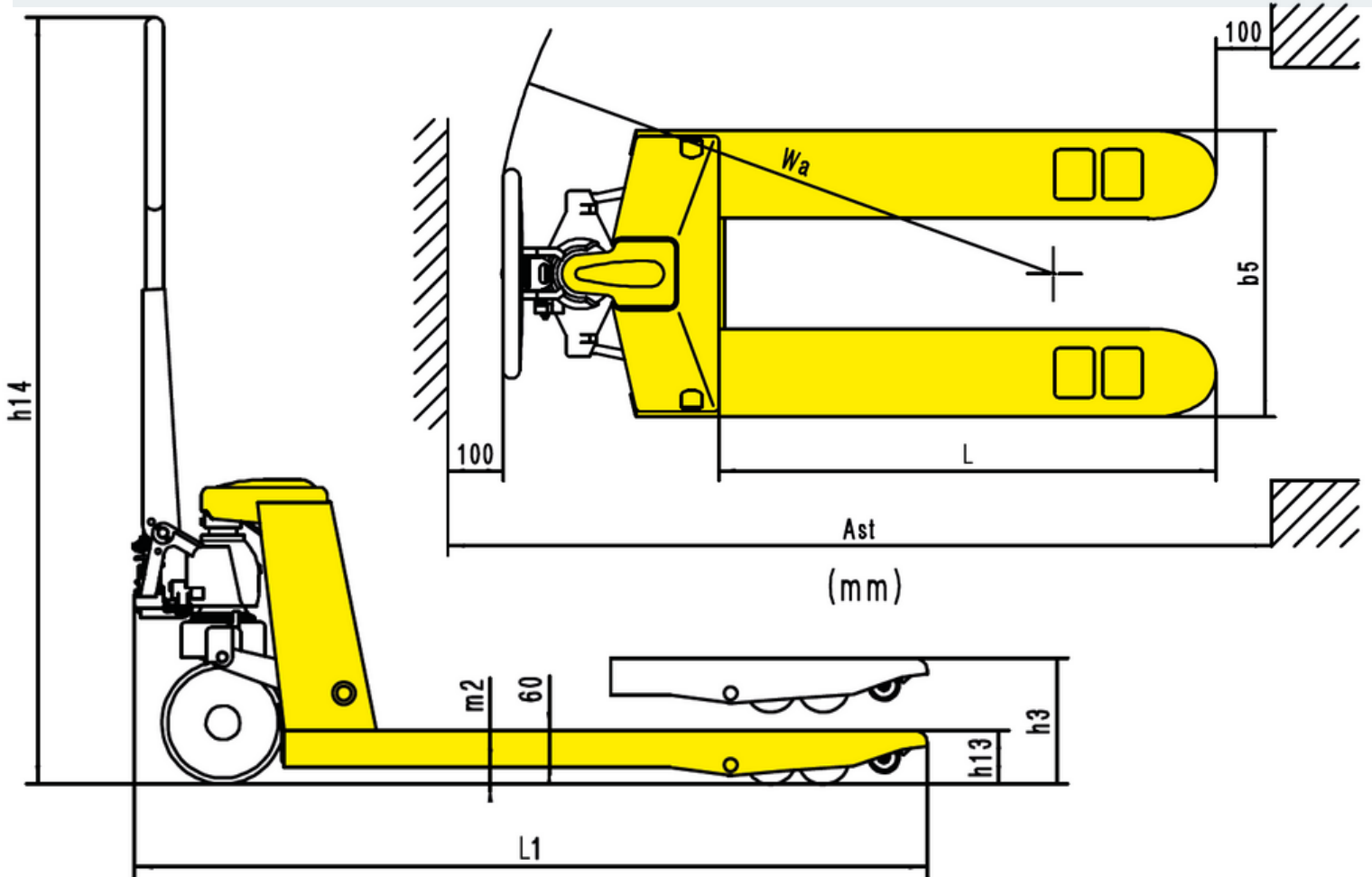

	MEASUREMENT IN INCHES	MEASUREMENT IN MILLIMETER (MM)		MEASUREMENT IN INCHES	MEASUREMENT IN MILLIMETER (MM)
Lowered fork height (h13)	3.34"	85MM	Width overall forks (b5)	26.97"	550/685 MM
Max. lift height (h3)	7.87"	200 MM	Ground clearance, centre of wheelbase (m2)	1.10"	28 MM
Total height (h14)	49.33"	1253 MM	Aisle width for pallets 1000x1200 crossways (Ast)	71.42"	1744/1814 MM
Overall length (l1)	63.54"	1544/1614 MM	Aisle width for pallets 800x1200 lengthways (Ast)	71.42"	1744/1814 MM
Fork length (L)	48.03"	1150/1220 MM	Turning Radius (Wa)	53.94"	1300/1370 MM
Fork wheel tandem	3.15" X 2.91"	φ80x74 MM	Capacity	7,000 LBS 3.5 Tons 3,175.18 KG	
			Steering wheel	φ200 MM	
			Service weight	220LBS, 100 KG	